

# McFiver™ PCIe® Card

## Quick Start Guide

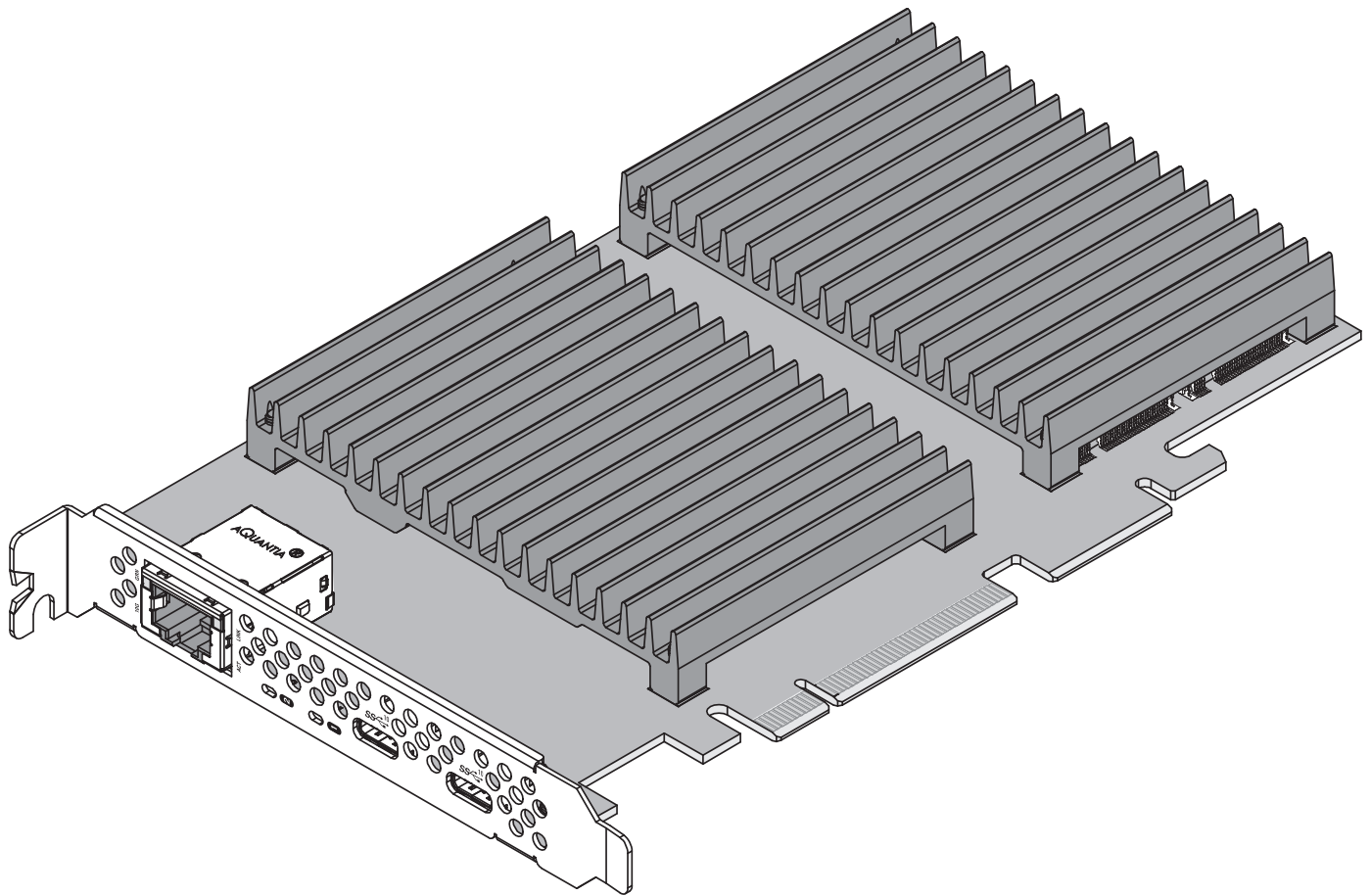

**Support Note:** This document was up to date at the time of printing. Please check the Sonnet website for the latest documentation.

1. Go to [www.sonnettech.com/support/kb/kb.php](http://www.sonnettech.com/support/kb/kb.php)
2. Navigate to and click the McFiver PCIe Card link.
3. Click the Manual link.
4. Click the McFiver PCIe Card Quick Start Guide [English] link, and then check the Document Version information. If the version listed is later than this document (**revision E**), click the Download Now button for the latest version.

**PCI EXPRESS®**



For  
Windows



**SONNETTECH™**

## Introduction, Compatibility Information, and Card Description

Congratulations on your purchase! The McFiver PCIe Card provides a handy way to install one or two M.2 form factor NVMe SSDs into a PCIe slot, and includes two 10Gbps USB 3.2 Gen 2 ports and one 10 Gigabit Ethernet (10GBASE-T) port. macOS®, Windows®, Linux®, and Thunderbolt™ compatible, this card works in computers and Thunderbolt-to-PCIe card expansion systems.

### Mac® Compatibility

- Mac Pro® 14,8 (2023); macOS 13 – macOS 14
- Mac Pro® 7,1 (2019); macOS 12\*
- Some SSDs are not currently compatible with macOS. See link to M.2 SSD compatibility list below.

### Windows Compatibility

- Computer with available full-height x8 PCIe card slot (PCIe 3.0 or 4.0 slot preferred; PCIe bifurcation not required)
- Windows 11, 10
- Windows Server 2022, 2019

### Linux Compatibility

- Computer with available full-height x8 PCIe card slot (PCIe 3.0 or 4.0 slot preferred; PCIe bifurcation not required)
- Linux Kernel 5.4+

### Thunderbolt Compatibility

- Mac computer with Thunderbolt ports via a Thunderbolt-to-PCIe card expansion system with available full-height x8 PCIe card slot: macOS 12 – macOS 14
- Windows 11 (22H2 and later) computer with Thunderbolt ports via a Thunderbolt to PCIe card expansion system with available x8 PCIe card slot
- Windows 10 computer with Thunderbolt ports via a Thunderbolt to PCIe card expansion system with available x8 PCIe card slot: all supported Windows versions
- Linux computer with Thunderbolt ports via a Thunderbolt to PCIe card expansion system with available full-height x8 PCIe card slot

### M.2 SSD Compatibility

To view a list of known compatible M.2 2280 NVMe PCIe SSDs, visit [https://sonnettech.com/support/downloads/manuals/M2\\_compatibility.pdf](https://sonnettech.com/support/downloads/manuals/M2_compatibility.pdf)

### RAID Configuration Support Information

McFiver PCIe Card supports RAID 0, RAID 1, and concatenated disk set configurations of SSDs.

\* macOS 13 and macOS 14 do not currently support NVMe SSDs installed in a PCIe slot of the Mac Pro 7,1 (2019). Sonnet is working with Apple to resolve the issue.

## Introduction, Compatibility Information, and Card Description

### Card Description – Ports and Indicators

#### 1 – RJ45 (10GBASE-T) Port

For 10 Gigabit Ethernet support, connect a Cat 6 or better cable between this port and the switch's or device's RJ45 port. 5 Gigabit and lower speeds are supported by Cat 5e and better cabling.

#### 2 – Link Speed Indicator

When an Ethernet link is established between the McFiver card and the switch, this LED lights to indicate the link speed to the switch: green = 10Gb, yellow = 5Gb, 2.5Gb, 1Gb, and 100Mb.

#### 3 – Activity/Link Indicator

This LED lights up green to indicate a link is established between the McFiver card and the switch.

#### 4 – SSD Read/Write Activity LEDs

Indicate read and write activity by SSD.

#### 5 – 10Gbps USB-C Ports

Connect USB devices to these ports. These ports provide up to 7.5W to bus-powered peripheral devices.

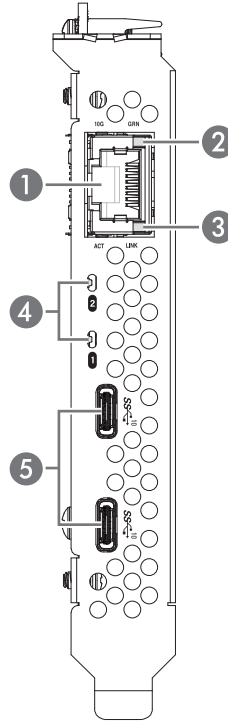

## SSD Installation Steps

The following steps cover installing SSDs on the card. If you are not installing SSDs, skip to page 8.



**Support Note:** When handling computer products, you must take care to prevent components from being damaged by static electricity. Before opening your computer or removing parts from their packages, always ground yourself first by touching a metal part of the computer, such as a port access cover, and work in an area free of static electricity; avoid carpeted areas. Handle all electronic components by their edges, and avoid touching connector traces and component pins.

1. Handling it by its edges, remove the McFiver PCIe Card from its packaging.
2. Using a Phillips screwdriver, remove the four screws securing the SSD heatsink to the card (Figure 1). Set aside the heatsink and screws.
3. Remove the two screws from the SSD support bracket as shown (Figure 2). Set aside the screws.

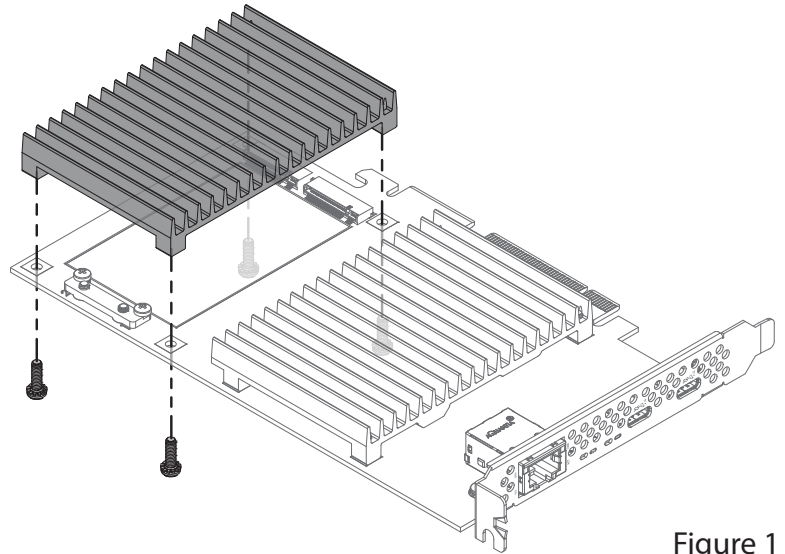

Figure 1

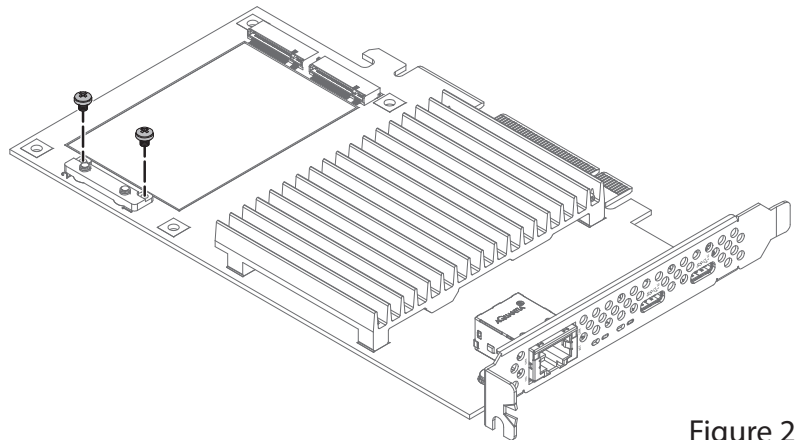

Figure 2



**WARNING:** When installing single-sided SSDs, you are required to install the included thermal transfer pad on the card before installing SSDs. Failure to do so may result in poor performance.

4. Determine whether you are installing single- or double-sided SSDs (larger components on one or both sides). If you are installing single-sided SSDs, remove the included thermal transfer pad from its packaging. If you are installing double-sided SSDs, skip to step 11.
5. Carefully peel off the backing material from *one* side of the pad.
6. Starting with one edge, carefully apply the pad to the card inside the rectangular outline between the SSD sockets and the SSD support bracket; be sure to avoid trapping air bubbles (Figure 3).
7. Rub the pad all over to ensure its complete contact with the card.

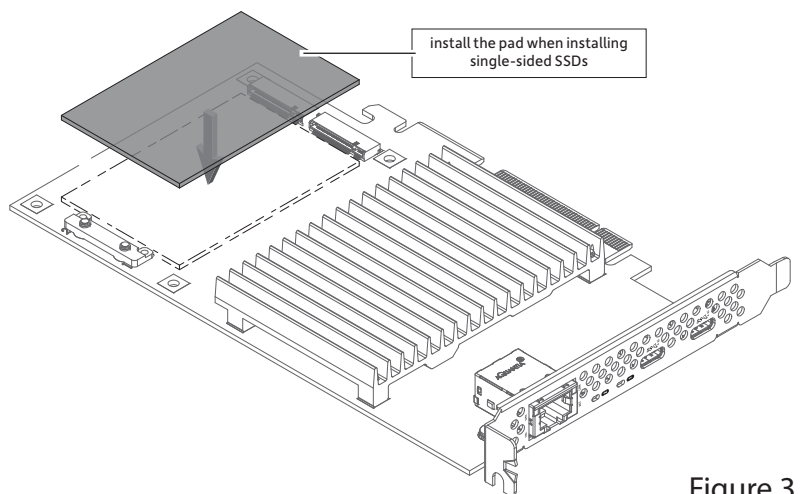

Figure 3

## SSD Installation Steps

8. Peel off the backing material from the top of the pad you just installed (Figure 4).

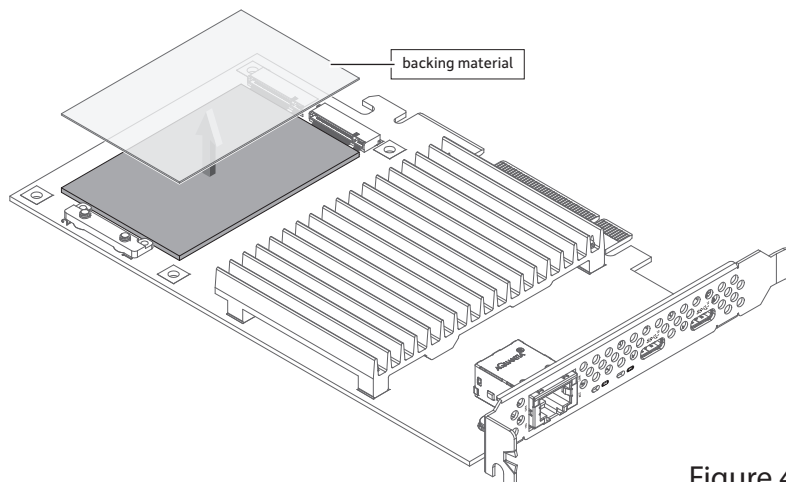

Figure 4

9. If you are installing two SSDs now, skip to step 11. Otherwise, cut the backing material in half lengthwise as shown (Figure 5).

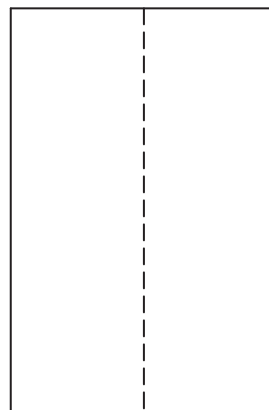

Figure 5

10. Reapply the half piece of backing material to the thermal transfer pad on the side where no SSD will be installed (Figure 6). By reapplying the backing plastic, you will protect the sticky thermal pad from collecting dust, leaving it clean for when you are ready to install a second SSD.

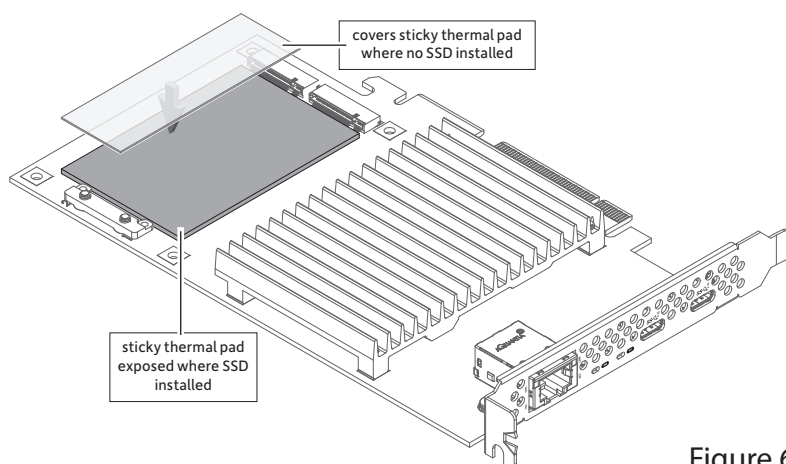

Figure 6

## SSD Installation Steps

11. Handling it by its edges, remove an SSD from its packaging.
12. Insert the SSD into one of the SSD sockets until it snaps into place (Figure 7). If you are installing only one SSD, install it where the sticky side of the thermal transfer pad is exposed.
13. Repeat steps 11 and 12 if you are installing a second SSD.

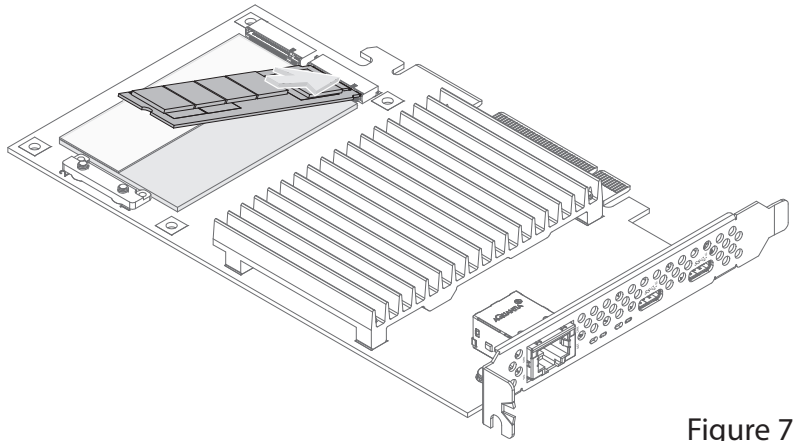

Figure 7

14. Using the two screws you removed previously, secure the SSD(s) to the SSD support bracket (Figure 8); do not overtighten the screws. If you installed only one SSD, reinstall the remaining screw into the open hole.

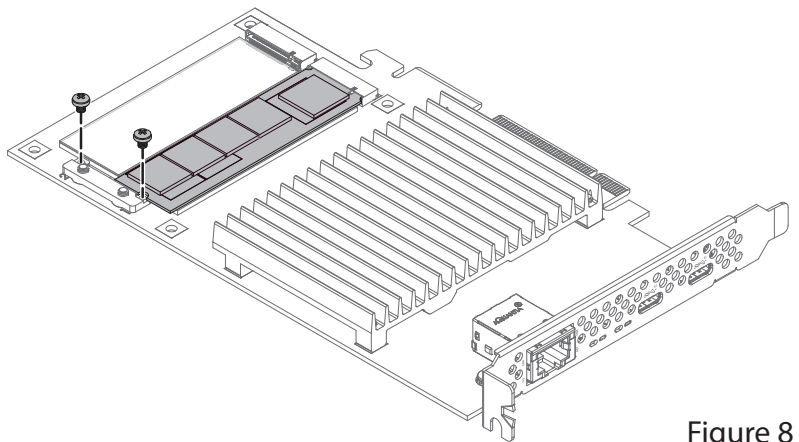

Figure 8

15. Peel off the backing material from the thermal transfer pad attached to the heatsink (Figure 9).

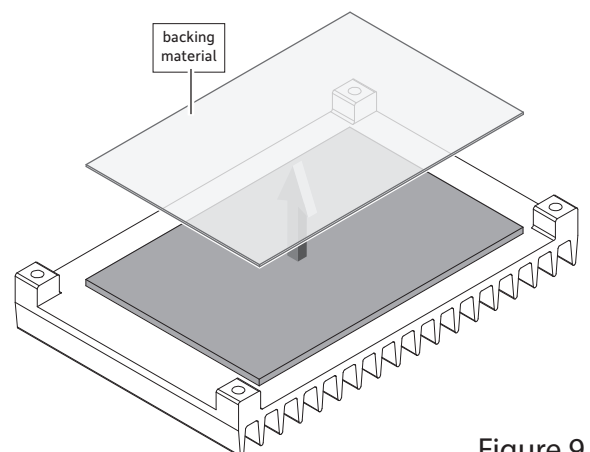

Figure 9

## SSD Installation Steps

16. If you installed two SSDs, skip to step 18. Otherwise, cut the backing material in half lengthwise as shown (Figure 10).

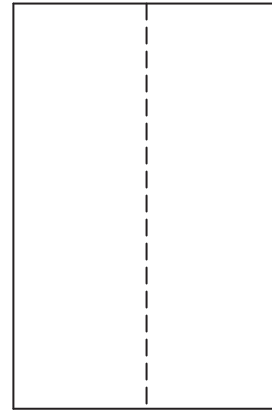

Figure 10

17. Reapply the half piece of backing material to the heatsink's thermal transfer pad on the side of the pad that will *not* contact the SSD (Figure 11). Note that by reapplying the backing plastic, you will protect the sticky thermal pad from collecting dust, leaving it clean for when you are ready to install a second SSD.

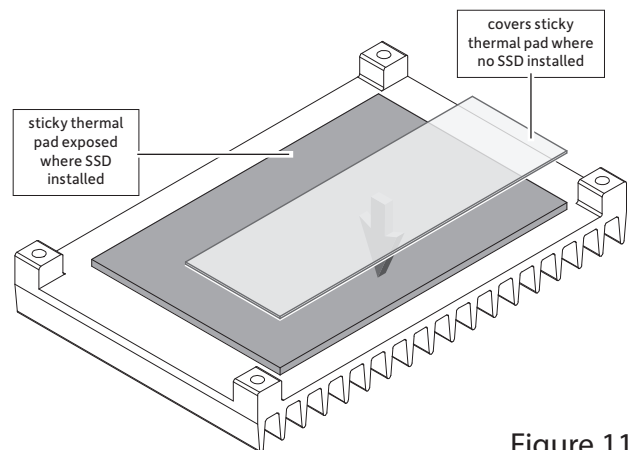

Figure 11

18. Set the heatsink on top of the card, aligning the threaded holes in the heatsink with the corresponding holes in the card as shown (Figure 12).
19. Holding them firmly against each other, flip over the card and the heatsink.
20. Secure the heatsink to the card with the four screws you removed previously (Figure 12); do not overtighten the screws.

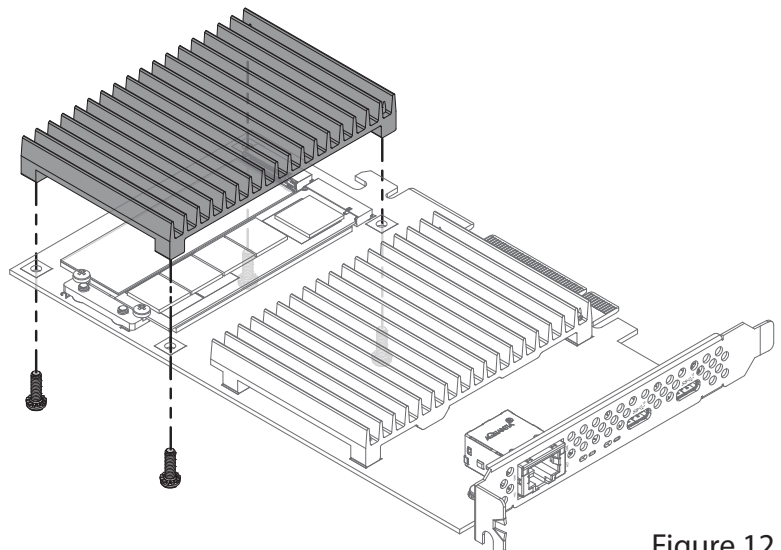

Figure 12



**Support Note:** After securing the heatsink to the card, it is normal and safe for the card to bend a small amount. This is normal and not a cause for concern.

## Card Installation, SSD Formatting and Configuring Steps

### Card Installation Steps

1. Shut down your computer or expansion chassis, disconnect its power cable, and then open it to access the expansion card area (PCI Express slots); refer to the user manual for specific information.
2. Locate an available x8 or x16 PCIe slot and remove its access cover if necessary.
3. Install the Sonnet card into the slot; make sure the card is firmly seated and secured.
4. Close your computer or expansion chassis.
5. Reconnect the computer's or expansion chassis' power cable.
6. If you are using the McFiver card's Ethernet port, connect a Cat 6A, Cat 6, or Cat 5e cable (depending on the network connection and distance) between the port on the card and a port on the switch or device.



**Support Note:** 10 Gb/s speed supported on Cat 6a and Cat 6 cabling at 100 and 55 meters, respectively. Lower speeds supported on Cat 5e (and better) cabling at up to 100 meters. 5 Gb/s and 2.5 Gb/s link speed support requires an NBASE-T (multi-Gigabit) compatible switch.

### Formatting and Configuring SSDs—macOS

Use Disk Utility (found in the Utilities folder within the Applications folder) to format installed SSDs. For step-by-step instructions on how to create RAID 0, RAID 1, or concatenated sets with installed SSDs, open Disk Utility, click Help and then select Disk Utility Help. In the *Disk Utility User Guide* window, type “create a disk set” and then press return. Click “Create a disk set using Disk Utility on Mac” to read the directions.

### Formatting and Configuring SSDs—Windows

If you intend to format SSDs connected to the Sonnet card using Windows drive formatting tools, you may use either Disk Management or Storage Spaces.

#### Basic RAID Configuration Steps for Windows

Assuming you have installed two SSDs, you may follow these instructions to format them into a RAID array (Storage Space).

1. Go to the taskbar, type Storage Spaces in the search box, and then select Storage Spaces from the search results list.
2. In the *Storage Spaces* window, click Create a new pool and storage space.
3. Click the check boxes next to the SSDs you want to add to the new storage space (RAID volume), and then click Create pool. Be very careful not to select a drive you don't want to include, and note that all data on the SSDs you include in a Storage Space will be erased.

4. Give the “drive” a name and letter, and then choose a file system.
5. From the Resiliency type drop-down, select Simple (RAID 0) or Two-way mirror (RAID 1).
6. Depending on the Resiliency type you chose, the wizard will set the maximum available disk capacity. If necessary, you can also enter the maximum size for the storage space. Click Create storage space to complete the formatting and configuration; your SSDs are ready to use.

### Formatting and Configuring SSDs—Linux

Use the tools or utilities you would normally use to format and configure internal drives.

### Booting From Attached SSDs

#### macOS:

McFiver PCIe Card supports booting from individual (non-RAIDed) SSDs when the card is installed in 2019 or 2023 Mac Pro computers or Thunderbolt to PCIe card expansion systems. Please note that in some cases it may be necessary for you to hold the *option* key during a start, and then select the startup disk attached to the Sonnet card.

If the McFiver card is installed in a Thunderbolt chassis and you are using a Mac with the Apple T2 Security Chip, then you must enable External Boot in the Startup Security Utility.

#### Windows and Linux:

McFiver PCIe Card supports booting from a single, non-RAIDed SSD *only* in computers with UEFI.

## Port Configuration, Tips, and General Information

### Basic Ethernet Configuration Information—macOS

Configure the Ethernet port's settings in the System Preferences Network preferences panel; the card is identified as a PCI Ethernet card.

### Ethernet Performance Tuning Steps—macOS

Listed below are steps required to configure the McFiver PCIe card for maximum performance. Please note that to take advantage of these settings, the switch or router to which the card is connected must also support these features.

1. Open System Preferences, and then click Network. In the Network System Preferences panel, click the Sonnet card's port in the left panel, and then click Advanced; a new panel appears.
2. In the Advanced panel, click Hardware. From the Configure drop-down menu, select "Manually". In the Speed drop-down menu, leave the setting at, or select 10GbaseT (or 5000baseT or 2500baseT if either is the top speed your network connection supports). In the Duplex drop-down menu, select "full-duplex" (*not* "full duplex, flow-control"). In the MTU drop-down menu, select "Custom," and then select "Jumbo" or enter "9000" in the box below.
3. When you've finished changing the settings, click OK. Back in the main Network window, click Apply after you've completed changing the settings; your setup is complete.



**Support Note:** For additional info on improving throughput under macOS, visit the McFiver PCIe Card support page.

1. Go to [www.sonnettech.com/support/kb/kb.php](http://www.sonnettech.com/support/kb/kb.php)
2. Navigate to and click the McFiver PCIe Card link, and then click the FAQ link.
3. Click the link for article ID 814.

### Basic Ethernet Configuration Information—Windows

You may configure the Ethernet port's settings using Windows Device Manager. You may locate the card in the Network adapters Category, listed as Marvell FastLinQ Edge 10Gbit Network Adapter.

### Basic Ethernet Configuration Information—Linux

The steps necessary to configure the Ethernet port with your computer may vary based on the version of Linux running. Sonnet recommends using whatever method or tools you would normally use for configuring any onboard ports.

## ETHERNET TIPS, GENERAL INFORMATION

### 5 Gb/s and 2.5 Gb/s Link Speed Support

The McFiver PCIe Card supports 5 Gb/s and 2.5 Gb/s link speeds when used with NBASE-T compatible (multi-Gigabit) switches, and connected via Cat 5e (or better) cabling.

### Audio Video Bridging (AVB) Support

The McFiver PCIe Card supports AVB under macOS when used with an AVB-compatible (802.1Qav) switch plus infrastructure.

### Internal Storage Use—Known Limitations and Advice for Mac Users

- Although there is no provision in macOS to make SSDs on a PCIe card appear as internal and non-ejectable, you may prevent accidental ejection by opening a file on the volume with Text Edit. Leaving the file open will prevent macOS from ejecting the volume because the file will be in use by the application.

### USB Ports—Known Limitations & Advice for All Users

USB peripherals have some limitations you should be aware of, and we have listed some additional advice here. Refer to the peripheral manufacturers' Web sites for more information.

- Most USB 3.2 (formerly 3.1) devices come in two varieties, Gen 1, and Gen 2. Gen 1 devices support data transfer speeds up to 5Gbps, while Gen 2 devices (such as this Sonnet adapter card) support data transfer speeds up to 10Gbps.
- The use of USB-C to USB-A cables is supported, but data transfer speeds are limited to speeds supported by the cable and device.
- The McFiver card's USB-C ports do not support Thunderbolt-only peripheral devices, even though they use the same connector. If the peripheral device only has the Thunderbolt icon (⚡) next to its port(s), or on the connector of an attached cable, it will not work with the Sonnet card.

## Support Information

### Contacting Customer Service

The Sonnet Web site located at [www.sonnettech.com](http://www.sonnettech.com) has the most current support information and technical updates. Before contacting Customer Service, please check our Web site for the latest updates and online support files, and check this Quick Start Guide for helpful information.

Email support requests generally receive the fastest responses, and are usually processed within a 24-hour period during normal business hours, excluding holidays. When you contact Customer Service, have the following information available so the customer service staff can better assist you:

- Product name
- SSD model(s)
- Computer model
- OS version
- A System Report (macOS), or a Microsoft System Information MSINFO32 (Windows) report (Windows), along with a description of the issue(s) you are encountering with your device

If further assistance is needed, please contact **Sonnet Customer Service** at:

E-mail: [support@sonnettech.com](mailto:support@sonnettech.com)

Tel: 1-949-472-2772

(Monday–Friday, 9 a.m.–5 p.m. Pacific Time, excluding holidays)

### Japan Customers

Contact Sonnet Customer Service Japan at:

E-mail: [jp.support@sonnettech.com](mailto:jp.support@sonnettech.com)